

TB 132A

TECHNICAL BULLETIN

INFORMATION ONLY

For the Attention of : Service Engineers, Installers, Trade Customers, Training Dept.

Date : 12/07/12

Product : Midilift XL+

Subject : Addition of cabin roof stop switch (revision A)

Pages : 1 of 1

Originator : Stannah Lifts Ltd, Anton Mill, Andover, Hants SP10 2NX 01264 339090

This revised technical bulletin replaces previously issued TB132. The original bulletin contained the following statement –

Activation of the stop switch will force the control to latch out of service and will be displayed as an ‘anti-surf’ fault. A power cycle is required to return the lift to normal use.

This is incorrect – activation of stop switch will prevent further movement of the lift with no fault code displayed. When released, the lift will return to normal service.

Detail:

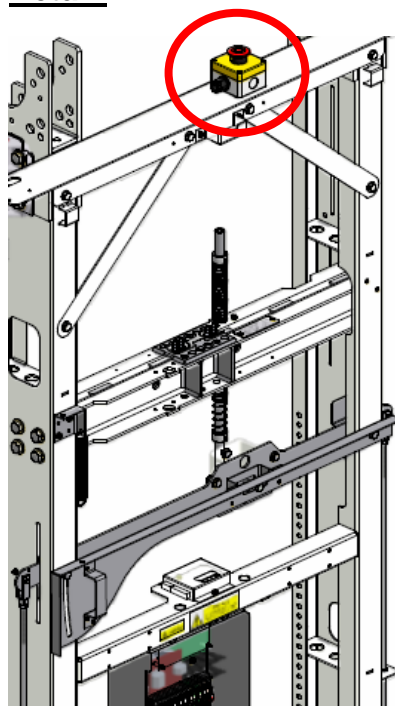

All Midilift XL+ lifts manufactured after 11/06/12 will have a cabin roof stop switch installed as standard.

The stop switch has been integrated into the safety chain and is located between ‘G7D’ and ‘G8’ terminals.

Specific connection details can be found in the wiring manual supplied with the lift.

IMPORTANT NOTE: The inclusion of the stop switch does not alter any safe working procedures for the Midilift XL+. **Car top working is strictly prohibited.**